

SQR-C 撓性聯軸器 / Jaw Coupling

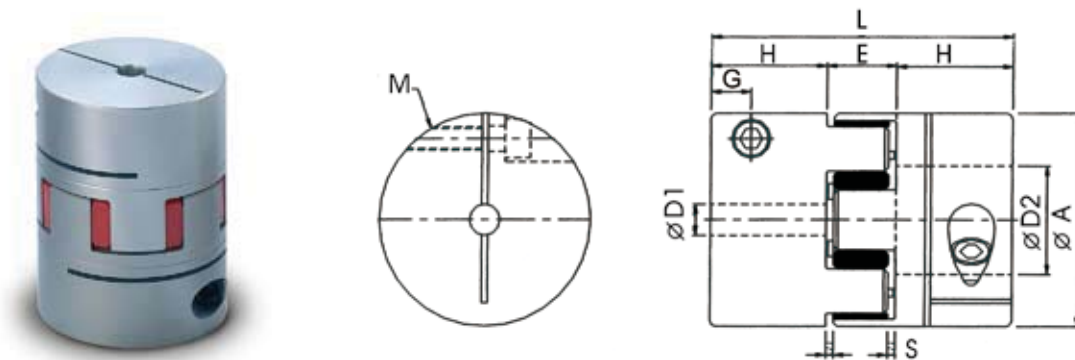

SQR- C- D1 - D2

外徑
Diameter

◆尺寸表 / Dimension

單位 / unit:mm

規格 No.	A	G	D1		D2		E	H	S	L	M
			min	max	min	max					
SQR-30C	30	5	6	15	6	15	13	11	1.5	35	M4
SQR-40C	40	8.5	8	20	8	20	16	25	2	66	M5
SQR-55C	55	10.5	10	25	10	25	18	30	2	78	M6
SQR-65C	65	13	12	35	12	35	20	35	2.5	90	M8
SQR-80C	80	14	16	45	16	45	24	45	3	114	M10
SQR-95C	95	16	20	55	20	55	26	50	3	126	M10

◆特性表 / Specification

規格 No.	常用扭力 Rated Torque (N.m)	最大扭力 Max. Torque (N.m)	容許誤差 Allowable Errors			最高轉速 Max. Rotational (rpm)	剛性靜扭力值 Static Torsion Rigidity (N.m/rad)	慣性矩 Moment of Inertia (Kg.m ²)	重量 Weight (g)
			偏心 Error of Eccentricity (mm)	偏角 Error of Angularity (o)	軸向位移 Axial End-Play (mm)				
SQR-30C	12.5	25	0.1	1	+1.0	10000	135	6.2×10^{-6}	40
SQR-40C	17	34	0.1	1	+1.2	10000	1100	3.9×10^{-5}	150
SQR-55C	60	120	0.1	1	+1.4	7000	3200	1.6×10^{-4}	350
SQR-65C	160	320	0.1	1	+1.5	5900	4900	3.8×10^{-4}	500
SQR-80C	325	650	0.1	1	+1.8	4800	7400	1.1×10^{-3}	1000
SQR-95C	450	900	0.1	1	+2.0	3600	14000	1.9×10^{-3}	1500

◆特性 / Features

- 高扭力，高剛性 / High Torque, High Rigidity
- 可正逆轉特性 / High Clockwise and Anticlockwise Rotational Characteristics
- 低慣性，無背隙 / Low Inertia, Backlash-free
- 適用於伺服馬達或精密定位傳動 / Applicable for Servo Motor or Precise Positioning Transmission
- 免保養，壽命長 / Maintenance-free; Infinite Life
- 固定方式：夾緊式 / Fix Type : Clamping
- 本體：鋁合金材質 / Body : Aluminum Alloy Body ; Light-weight
- 使用溫度範圍-30℃~100℃ / Working range, -30℃~100℃ Temperature