

扭力限制器 Torque Limiter

精密定位扭力限制器 / Accuracy Positioning Type



● STF系列 / STF Series

STF 法蘭型系列附有法蘭面，可裝配平台、齒輪、鏈輪使用，此項過負荷保護，針對旋轉垂直方向出力有效，在正常使用下，可精確傳達扭力，且無背隙減少動作上的耗損。

STF Series, the flanged type, can be used to platform, gear and sprocket. It provides overload protection to rotationwise and verticalwise power output. In normal usage, it can precisely transmit torque, and lower the loss of drive without backlash.



● STC系列 / STC Series

STC 聯軸型系列適用於軸與軸聯結，此項過負荷保護，針對旋轉垂直方向出力有效，具備吸收軸與軸之間排列落差特性。

STC Series, the coupling type provides shaft-to-shaft connection, and overload protection to rotationwise and verticalwise power output. It can absorb the shaft-to-shaft misalignment.

扭力限制器精度 Accuracy of Torque Limiter

規格 No.	ST4F~ST5F	ST6F~ST18F	ST4C~ST5C	ST6C~ST18C
定位精度 Accuracy of Positioning	1~2mim	30sec	1~2mim	30sec
重現精度 Accuracy of Repeatability	30sec	15sec	30sec	15sec

選用方式 Ordering Specification

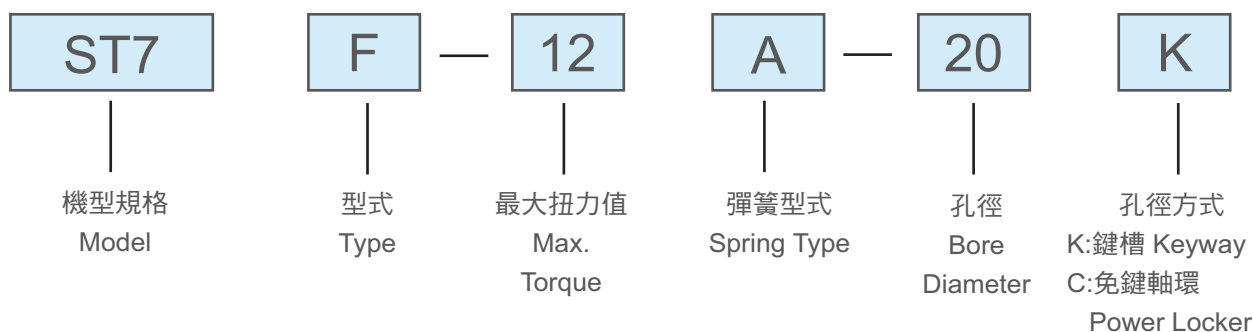

STF 精密定位型扭力限制器 / Accuracy Positioning Type

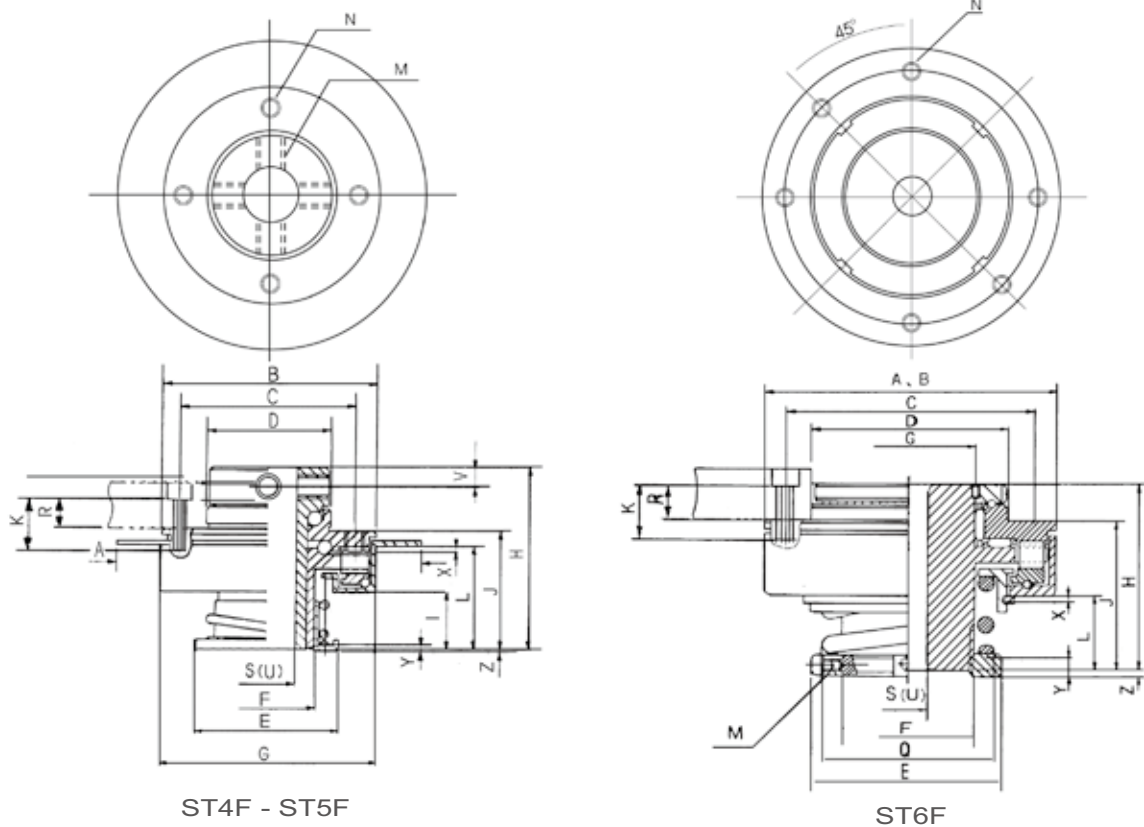

ST4F - ST5F

ST6F

◆尺寸 / Dimension

尺寸單位：mm

規格 No.	扭力 T kg.m	A	B	C	D	E	F	G	H	I	J	K*	L	M	N	Q	S	U	V	X	(Z)
ST4F-007C	0.03~0.07									11.2			21.2							1.1	0.7
ST4F-010C	0.04~0.10	64	64	PCD 36	26 h7	32	M20 P1	46	38	11.4	25	R+4.5	21.4	4.M5 P0.8	4-M4 P0.7 深4.7		7	12	4	1.3	0.5
ST4F-030C	0.1~0.30									11.2			21.2							1.1	0.7
ST4F-045C	0.15~0.45									11.4			21.4							1.3	0.5
ST5F-030C	0.08~0.30									17.5			29.0							0.9	1.3
ST5F-060C	0.15~0.60	82	63	PCD 50	35 h7	45	M30 P1.5	63	50	18.0	34	R+5.5	29.5	4.M6 P1	4-M4 P0.7 深5.7		9	20	6	1.4	0.8
ST5F-100C	0.20~1.00									17.5			29.0							0.9	1.3
ST5F-180C	0.40~1.80									18.0			29.5							1.4	0.8
ST6F-07C	0.2~0.7												25.0							1.3	3.9
ST6F-1C	0.3~1.0	88	88	PCD 75	60 h7	58	M40 P1.5	M40 P1.5	60		48	R+7	25.5	2.M5 P0.8	6-M6 P1 深7		12.5	27		2.0	3.2
ST6F-3C	1.0~3.0												25.0							1.3	3.9
ST6F-5C	1.5~5.0												25.5							2.0	3.2
ST7F-7A	2.2~7												30.0							1.6	1.7
ST7F-12A	4~12	128	113	PCD 95	75 h7	88	55 M52 P1.5		70		55	R+9	31.0	2.M5 P0.8	6-M6 P1 深9	102	16.5	35		2.5	0.9
ST7F-25B	8~25												30.0							1.6	1.4
ST7F-40B	12~40												31.0							2.5	0.6
ST8F-12A	5~12												37.5							1.6	0
ST8F-20A	7~20	164	138	PCD 120	100 h7	109	75 M72 P1.5		82		65	R+11	38.5	2.M5 P0.8	6-M8 P1.25 深11	130	16.5	48		2.5	-0.8
ST8F-40B	12~40												37.5							1.6	-0.7
ST8F-60B	20~60												38.5							2.5	-1.5
ST11F-25A	8~25												42.0							2.0	2.0
ST11F-35A	12~35	198	170	PCD 148	120 h7	134	96 M90 P1.5		95		75	R+13	43.0	2.M5 P0.8	6-M10 P1.5 深13	160	16.5	62		3.0	1.0
ST11F-85B	22~85												42.0							2.0	-0.5
ST11F-120B	35~120												43.0							3.0	-1.5
ST14F-30A	11~30												43.5							2.6	3.8
ST14F-45A	15~45	236	206	PCD 180	150 h7	158	120 M120 P2		105		85	R+15	45.0	2.M5 P0.75	6-M12 P1.75 深15	186	30	90		4.0	2.4
ST14F-120B	42~120												43.5							2.6	2.8
ST14F-180B	60~180												45.0							4.0	1.4
ST18F-130A	40~130												59.0							3.3	5.0
ST18F-180A	80~180	280	252	PCD 215	180 h7	220	165 M140 P2		135		110	R+17	60.5	2.M5 P0.75	6-M16 P2 深20	236	50	110		5.0	3.3
ST18F-300B	150~300												59.0							3.3	5.2
ST18F-500B	300~500												60.5							5.0	3.5

註*：安裝時特別注意螺絲長度。

STF 精密定位型扭力限制器 / Accuracy Positioning Type

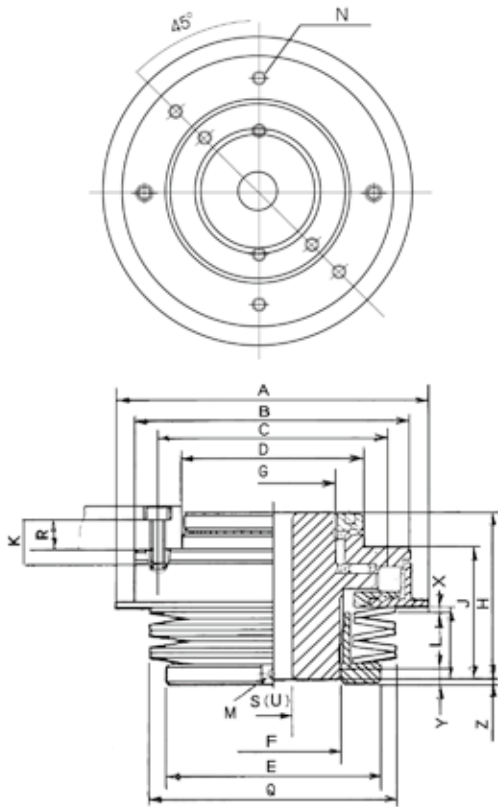

ST7F - ST18F

◆注意事項 / Note

- T : 使用扭力的調整範圍 / Adjustment Range of Applied Torque
- S : 預鑽孔尺寸 / Bore Size
- U : 最大加工孔徑尺寸 / Max. Machined Bore Size
- Kmax : 固定螺絲最大長度(請配合N值使用)
Max. Fixing Screw Length (in compliance with N value)
- X : 過負荷作用時，過負荷檢出盤移動距離，請使用近接開關於迴轉驅動機構上
Moving Range of Overload Detector in the event of overload. The proximity sensor can be applied to the rotation mechanism.
- Z : 扭力彈簧自由長時，驅動輪端面和壓緊螺帽端面的段差尺寸，使用此尺寸，算出設定扭力的基準值
The height between the surface of driving wheel and nut surface when torsion spring is at free length, the gap can be the reference to set torque.
- M : 固定壓緊螺帽的固定螺絲外徑與節距調整後請務必將固定螺絲鎖好
Fixing nut by the outer diameter and pitch of screw for fixing nut, be sure of locking the fixing screw after adjustment.
- Tmax : 最大傳達扭力 / Max. Transmissible Torque
- Ymax : 最大調整量 / Max. Adjustment Range
- P : 壓緊螺帽的螺紋節距 / Thread pitch for locking nut
- a : 最大容許軸向推力 / Allowable Max. Axial Thrust
- b : 最大容許側向推力 / Allowable Max. Later Thrust
- c : 最大容許彎曲力距 / Allowable Max. Twisting Torque
- Nmax : 最大容許回轉數 / Allowable Max. Rotational Frequency
- GD : 扭力限制器的慣性距 / Moment of Inertia of Torque Limiter

◆特性表 / Specification

規格 No.	Tmax kg.m	Ymax mm	p mm	a kgf	b kgf	c kgf.m	Nmax rpm	GD ² kgf.m ²	W kgf
ST4F-007C	0.07	3.3	1	7	40	0.35	2000	2.1×10 ⁻⁴	0.24
ST4F-010C	0.10	3.2							
ST4F-030C	0.30	3.3							
ST4F-045C	0.45	3.5							
ST5F-030C	0.30	4.3	1.5	11	58	0.70	1600	9.4×10 ⁻⁴	0.50
ST5F-060C	0.60	5.0							
ST5F-100C	1.00	6.8							
ST5F-180C	1.80	7.9							
ST6F-07C	0.7	12.0	1.5	390	810	12	800	5.2×10 ⁻³	1.5
ST6F-1C	1	11.0							
ST6F-3C	3	12.0							
ST6F-5C	5	11.0							
ST7F-7A	7	8.5	2	730	1100	20	600	1.9×10 ⁻²	3.4
ST7F-12A	12	8.0							
ST7F-25B	25	8.5							
ST7F-40B	40	7.5							
ST8F-12A	12	8.5	2	1050	1500	38	400	6.0×10 ⁻²	6.2
ST8F-20A	20	7.5							
ST8F-40B	40	8.0							
ST8F-60B	60	7.0							
ST11F-25A	25	13.0	2	1500	2250	68	300	0.14	11.4
ST11F-35A	35	12.0							
ST11F-85B	85	8.5							
ST11F-120B	120	7.5							
ST14F-30A	30	14.0	2	2400	2900	104	250	0.34	20
ST14F-45A	45	12.5							
ST14F-120B	120	13.0							
ST14F-180B	180	11.5							
ST18F-130A	130	13.0	2	3080	3600	147	180	1.2	42
ST18F-180A	180	11.5							
ST18F-300B	300	15.0							
ST18F-500B	500	13.5							

STC 精密定位型扭力限制器 / Accuracy Positioning Type

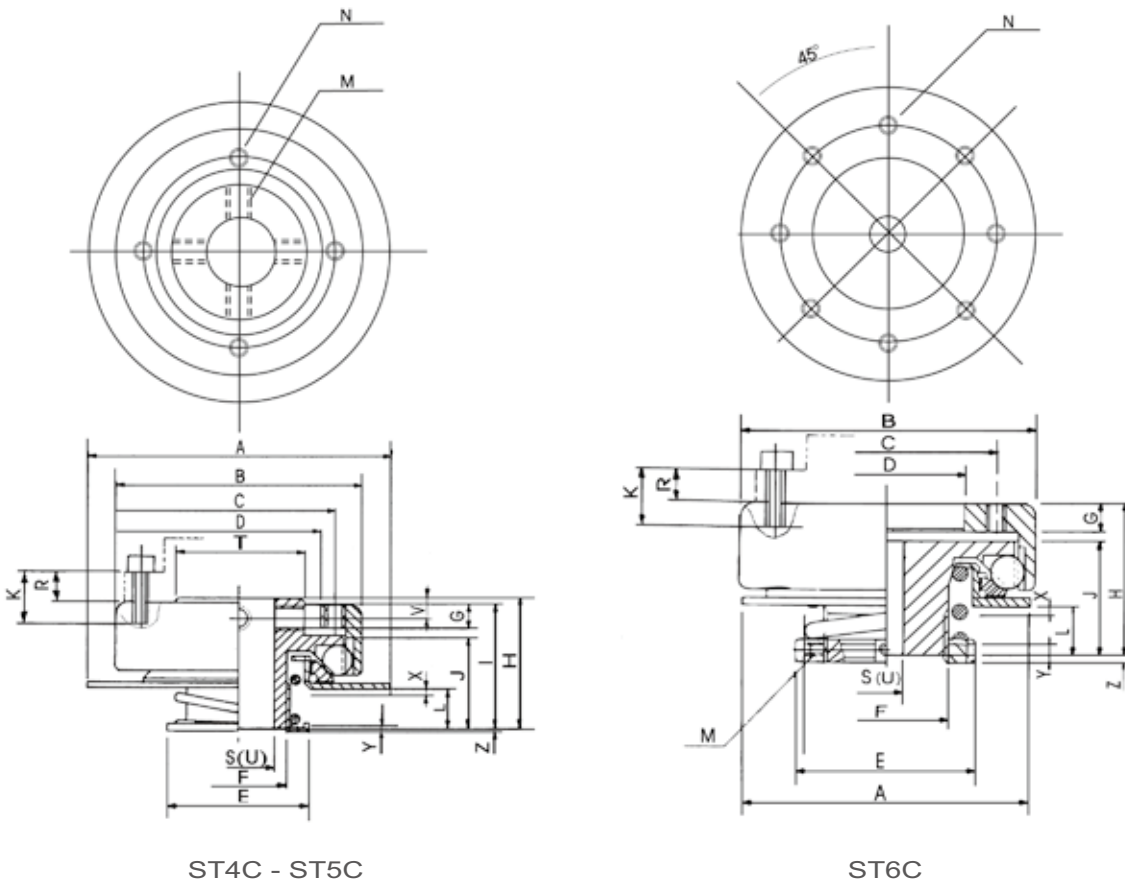

ST4C - ST5C

ST6C

◆尺寸 / Dimension

尺寸單位：mm

規格 No.	扭力 T kg.m	A	B	C	D	E	F	G	H	I	J	K	L	M	N	Q	S	U	V	T	X	(Z)	
ST4C-007C	0.03~0.07												7.6									0.7	0.6
ST4C-010C	0.04~0.10	64	52	PCD	34	32	M20	5	28	27	20.5	R+5	8.0	4.M5	4-M4		7	15	4.5	27	1.1	0.2	
ST4C-030C	0.1~0.30			40	H7		P1						7.6	P0.8	深4.7						0.7	0.6	
ST4C-045C	0.15~0.45												8.0								1.1	0.2	
ST5C-030C	0.08~0.30	82	71	PCD	46	45	M30	7	40	39	30	R+7	13.1	4.M6	4-M4		9	22	5.5	36	0.6	0.3	
ST5C-060C	0.15~0.60			55	H7		P1.5						13.7	P1	深5.7						1.2	-0.3	
ST5C-100C	0.20~1.00												13.1								0.6	0.3	
ST5C-180C	0.40~1.80												13.7								1.2	-0.3	
ST6C-06C	0.2~0.6	93	95	PCD	50	58	M40	9	52		40	R+8	18.5	2.M5	8-M6		12.5	27			1.4	3.2	
ST6C-1C	0.3~1.0			70	H7		P1.5						19.0	P0.8	P1						2.2	2.8	
ST6C-3C	1.0~3.0												18.5		深9						1.4	3.2	
ST6C-5C	1.5~5.0												19.0								2.2	2.8	
ST7C-6A	2~6	128	116	PCD	70	88	55	10	65		52	R+9	30.0	2.M5	8-M8		102	16.5	35		1.6	2.0	
ST7C-10A	3~10			90	H7								31.0	P0.8	P1.25						2.4	0.9	
ST7C-20B	6~20												30.0		深10						1.6	1.7	
ST7C-35B	10~35												31.0								2.6	0.6	
ST8C-12A	4~12	164	142	PCD	90	108	75	12	75		60	R+11	35.0	2.M5	8-M8		130	16.5	51		1.7	2.5	
ST8C-15A	6~12			110	H7								36.0	P0.8	P1.25						2.7	1.6	
ST8C-35B	10~35												35.0		深12						1.7	1.8	
ST8C-45B	12~45												36.0								2.7	0.9	
ST11C-20A	7~20	198	176	PCD	110	134	96	16	90		70	R+15	41.5	2.M5	8-M10		160	16.5	65		2.0	2.4	
ST11C-35A	10~35			130	H7								43.0	P0.8	P1.5						3.2	1.0	
ST11C-65B	20~65												41.5		深16						2.0	0	
ST11C-100B	30~100												43.0								3.2	-1.5	
ST14C-30A	10~30	236	208	PCD	130	158	120	16	100		80	R+15	44.0	2.M5	8-M12		186	16.5	90		2.7	4.5	
ST14C-45A	15~45			160	H7								44.0	P0.75	P1.75						4.3	4.5	
ST14C-130B	50~130												44.0		深16						2.7	3.5	
ST14C-200B	80~200												44.0								4.3	3.5	
ST18C-160A	70~160	285	285	PCD	170	220	170	18	130		108	R+17	59.0	2.M5	8-M16		236	50	130		3.7	4.8	
ST18C-250A	100~250			220	H7								59.0	P0.75	P2						6.2	5.0	
ST18C-380B	160~380												59.0		深18						3.7	5.0	
ST18C-500B	300~500												59.0								6.2	5.2	

STC 精密定位型扭力限制器 / Accuracy Positioning Type

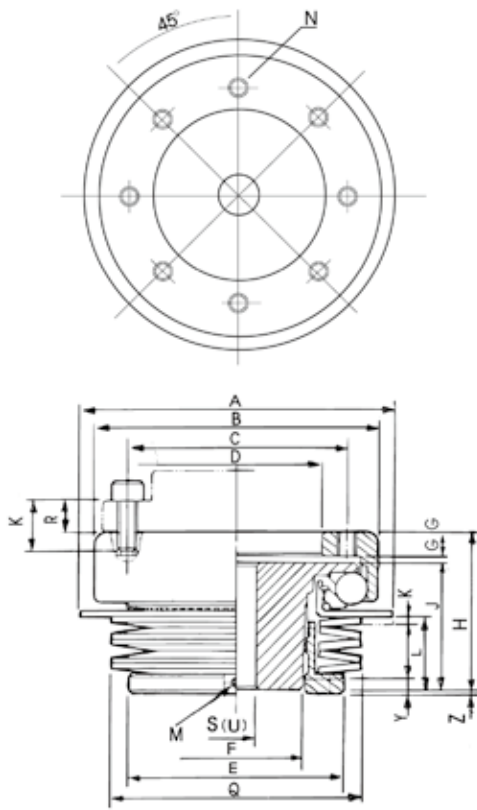

ST7C -ST18C

◆注意事項 / Note

- T : 使用扭力的調整範圍 / Adjustment Range of Applied Torque
 - S : 預鑽孔尺寸 / Bore Size
 - U : 最大加工孔徑尺寸 / Max. Machined Bore Size
 - Kmax : 固定螺絲最大長度(請配合N值使用)
Max. Fixing Screw Length (in compliance with N value)
 - X : 過負荷作用時，過負荷檢出盤移動距離，請使用近接開關於迴轉驅動機構上
Moving Range of Overload Detector in the event of overload. The proximity sensor can be applied to the rotation mechanism.
 - Z : 扭力彈簧自由長時，驅動輪端面與壓緊螺帽端面的段差尺寸，使用此尺寸，算出設定扭力的基準值
The hight between the surface of driving wheel and nut surface when torsion spring is at free length. The gap can be the reference to set torque.
 - M : 固定壓緊螺帽的固定螺絲外徑與節距調整後請務必將固定螺絲鎖好
Fixig nut by the outer diameter and pitch of screw, be sure of locking the fixing screw after adjustment.
 - Tmax : 最大傳達扭力 / Max. Transmissible Torque
 - Ymax : 最大調整量 / Max. Adjustment Range
 - P : 壓緊螺帽的螺紋節距 / Thread pitch for locking nut
 - θ : 偏角誤差的最大吸收量 / Max. Accommodation of Angularity Error
 - α : 隙縫誤差的最大吸收量 / Max. Accommodation of Clearance Error
 - Nmax : 最大容許回轉數 / Allowable Max. Rotational Frequency
 - GD : 扭力限制器的慣性距 / Moment of Inertia of Torque Limiter
- 註(1) / Note 1 :
隙縫誤差 α 的值是以組立尺寸H為基準的軸方向移動容許時請務必留意尺寸H
Clearance Error α is based on axial movement of Assembly Size H, be cautious of Assembly Size H
- 註(2) / Note 2 :
平行誤差 β 的值是扭力限制器的扭力傳達用滾珠的位置最大吸收量
Parallel Error β is the maximum accommodation of transmissible ball in torque limiter.
- 註(3) / Note 3 :
使用回轉數超過Nmax時，請先敝公司洽談
Please contact with us when the applied rotational frequency is greater than Nmax.

◆特性表 / Specification

規格 No.	Tmax kg.m	Ymax mm	p mm	a kgf	b kgf	c kgf.m	Nmax rpm	GD ² kgf.m ²	W kgf
ST4C-007C	0.07	4.0							
ST4C-010C	0.10	2.7	1	1	±1.0	0.1	2000	3.6×10 ⁻⁴	0.25
ST4C-030C	0.30	4.0							
ST4C-045C	0.45	3.3							
ST5C-030C	0.30	4.2							
ST5C-060C	0.60	5.9	1.5	1	±1.0	0.1	1600	1.6×10 ⁻⁴	0.68
ST5C-100C	1.00	6.8							
ST5C-180C	1.80	7.5							
ST6C-06C	0.6	11.0							
ST6C-1C	1	11.0	1.5	1.5	±1.5	0.1	1000	6.7×10 ⁻³	1.5
ST6C-3C	3	11.0							
ST6C-5C	5	11.0							
ST7C-6A	6	9.0							
ST7C-10A	10	8.0	2	1.2	±1.8	0.1	700	2.3×10 ⁻²	3.2
ST7C-20B	20	9.0							
ST7C-35B	35	7.5							
ST8C-12A	12	11.0							
ST8C-15A	15	10.0	2	1.2	±2	0.1	500	5.5×10 ⁻²	5.3
ST8C-35B	35	10.5							
ST8C-45B	45	9.5							
ST11C-20A	20	13.5							
ST11C-35A	35	12.0	2	1	±2.5	0.1	400	0.14	10.8
ST11C-65B	85	9.0							
ST11C-100B	100	7.5							
ST14C-30A	30	12.0							
ST14C-45A	45	12.0	2	0.7	±3.5	0.1	300	0.37	20
ST14C-130B	130	13.5							
ST14C-200B	200	13.5							
ST18C-160A	160	16.0							
ST18C-250A	250	16.0	3	1	±3.5	0.1	200	1.6	45
ST18C-380B	380	15.0							
ST18C-500B	500	15.0							

● 扭力限制器調整 / Adjusting Torque Limiter

使用扭力是指負荷超過此扭力時，入力側和出力側的傳達被脫離，STF、STC兩種機種具有調整扭力的機能，只要轉動兩機種的鎖緊螺帽就能簡單調整，但是無法表示出調整後的扭力值，所以請參考下圖可以推算出使用扭力，如果需要更正確的數值請使用扭力測定器等測定。Torque limiting disengages power input side and power output side when overload is greater than the applied torque. Both STF and STC provide the feature of torque adjustment by merely tightening or loosening the adjusting bolt on them. As to the applied torque value, please refer to the below charts. If you require the accurate torque value, please use the torque meter to obtain the torque measure.

● 扭力值調整使用例 / Torque Adjustment Guide

使用扭力和扭力彈簧調整量的關係，依據機種逐一表示。例如，需求使用扭力為30Kgf.m，選定本公司的扭力限制器ST8F-40B，於圖A求出扭力彈簧的鎖緊螺帽調整量。T=30Kgf.m.(點a)將點a水平延伸到ST8F-40B的曲線交點，作為點b。從點b再垂直往下求出點C，得到y=4.9mm(點c)，鎖緊螺帽的螺紋節距從STF型特性表可求出，所以扭力彈簧的鎖緊調整量Y除以螺紋節距P，可以求出鎖緊螺帽的調整迴轉量，換言之螺紋節距P=2mm時，鎖緊螺帽的調整迴轉量是從扭力彈簧變形量為零時位置開始大約轉2.4轉。

The relation between applied torque and torque spring adjustment of each model is presented respectively below. The required torque is 30 kgf.m, and the selected torque limiter is ST8F-40B. please see figure A, finding out the adjustment of packing bolt of torque spring. Torque = 30kgf.m (point a); parallel line from point a intersects with the curve line of ST8F-40B at point b; then vertical line from point b intersects with parallel axis at point c, y=4.9mm (point c), the thread pitch of packing bolt can be derived from the specification of STF type. Thus, Dividing Y, tightening adjustment of torque spring by P, thread pitch can get the rotational adjustment of packing bolt. In other words, if the thread pitch P is equal to 2mm, the rotational adjustment of packing bolt is that rotate the bolt 2.4 screw when the load on torque spring is zero.

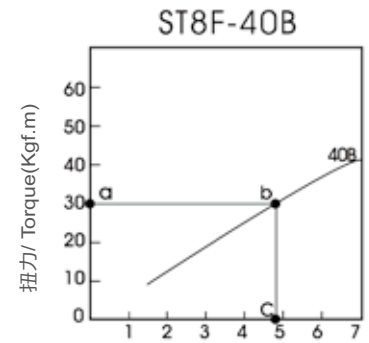

■ STF 型 / STF series

扭力值與鎖緊螺帽調整關係 Guide for Torque and Packing Bolt

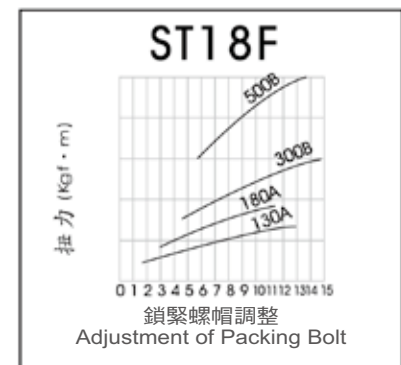
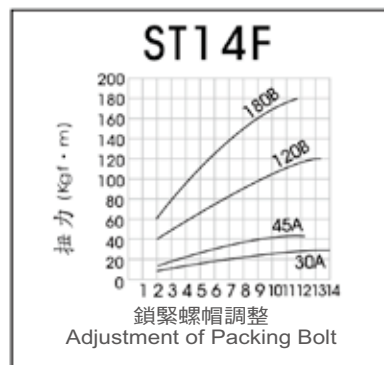
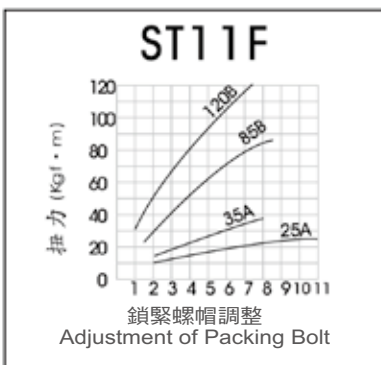
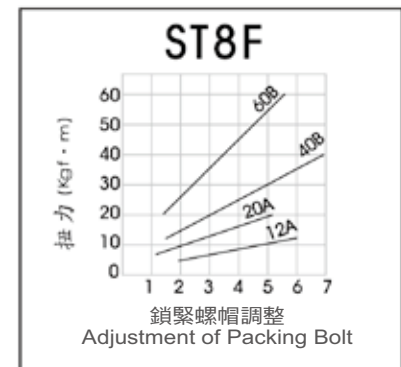
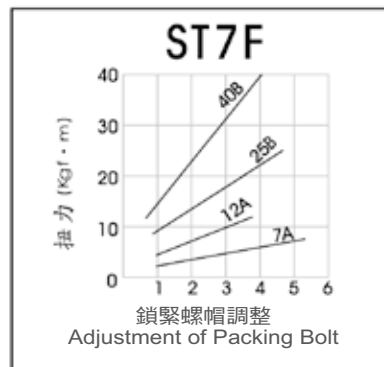
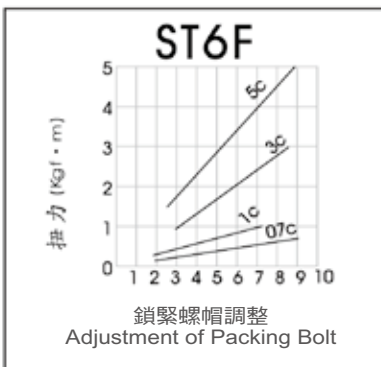
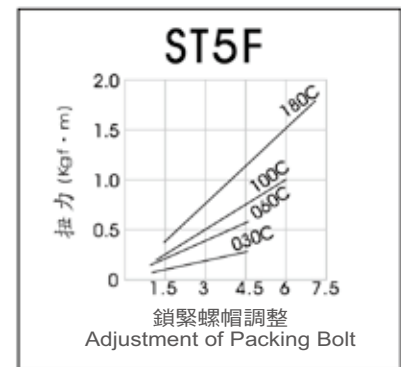
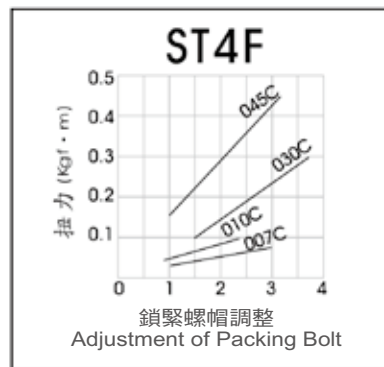

扭力限制器應用例 / Application for Torque Limiter

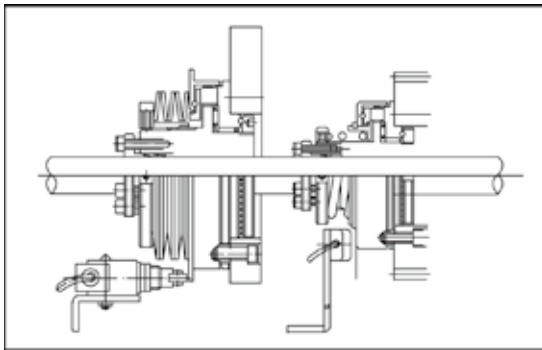

STF 安裝範例
Installation for STF series

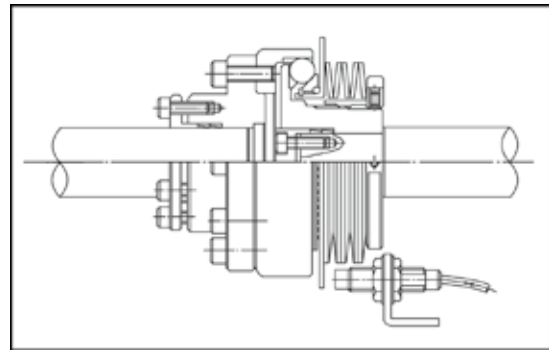

STC 安裝範例
Installation for STC series

STC 型 / STC series

扭力值與鎖緊螺帽調整關係
Guide for Torque and Packing Bolt

